

IP Transmitter

Model Tx4
5000W-2400V-20A

Instruction Manual



1963 rue Frank-Carrel, suite 203
Québec (Qc), Canada, G1N 2E6
Tel.: +1 (418) 478-5469

E-Mail: info@gddinstruments.com
Web site: www.gddinstruments.com

Visit our web site at:
www.gddinstruments.com

To:

- Discover GDD's new products.
- Download the latest version of the Instruction Manual.
- Comment on or ask questions about products.

TABLE OF CONTENTS

- 1. INTRODUCTION 4**
- 2. SAFETY 4**
- 3. TRANSMITTER DESCRIPTION 5**
 - 3.1 EQUIPMENT LIST 5
 - 3.2 TRANSMITTER COMPONENTS 5
- 4. TRANSMITTER OPERATION 11**
 - 4.1 STEPS TO FOLLOW 11
 - 4.2 OUTPUT POWER 11
- 5. GENERATOR CONNECTION 13**
 - 5.1 SINGLE-PHASE CONNECTION 13
 - 5.2 THREE-PHASE BASICS 13
 - 5.3 TRANSMITTER CONNECTION TO A THREE-PHASE GENERATOR 14
- 6. UPDATING THE FIRMWARE 15**
- 7. MASTER / SLAVE MODE 15**
- 8. MULTI-TX MODE 15**
- 9. TROUBLESHOOTING 15**
- 10. TECHNICAL HELP 15**
- 11. SPECIFICATIONS 15**
- 12. GLOSSARY 15**

1. INTRODUCTION

The GDD 5000W IP Transmitter, model Tx4, is used for time-domain induced polarization surveys. Its transmission cycle is 2 seconds ON, 2 seconds OFF. Other timings are available. It is sturdy and can operate in extreme climatic conditions (-40°C to 65°C).

The GDD 5000W-2400V-20A IP Transmitter can be powered directly from a 240VAC power source, such as a portable regulated generator. The Tx4 transmits up to 20A in a highly conductive ground or sends up to 2400V in a resistive ground for a total power of 5000W.

2. SAFETY

The GDD Tx4 is easy to use and it automatically stops within microseconds if a short circuit occurs or if the output wires are disconnected (open circuit). There is also an emergency stop button that shuts down completely and quickly all power inside the transmitter. However, and for user safety, we strongly recommend always wearing electrically insulated shoes and gloves while operating the transmitter.

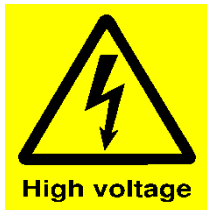

Safety hints:



Wear electrically insulated shoes. They should be approved by a certifying organization (CSA, ANSI) i.e. marked with the logo:



Wear electrically insulated gloves rated class 1 (7.5kV).

3. TRANSMITTER DESCRIPTION

3.1 Equipment list

When receiving a GDD 5000W-2400V-20A IP Transmitter, model Tx4, ensure that it contains the following elements:

- One (1) Tx4 Transmitter.
- One (1) 20A power cable.
- One (1) 20/30A cable adaptor.
- One (1) GDD Instruction manual.
- One (1) GDD Safe operating procedures (SOP).
- One (1) GDD blue carrying case.
- One (1) USB communication cable (type B)

Optional

- GDD Master/Slave cable.
- GDD Multi-Tx cable

Do not hesitate to communicate with Instrumentation GDD if needed.

3.2 Transmitter components

In this section, the Tx4 components from the control panel are shown, named and explained (refer to the picture on the next page).

3.2.1 **Output Terminals**

This is where the wires from the electrodes are connected. Press the button over each terminal to insert the wires. Be careful, the terminals can reach up to 2400V in stand alone mode and 4800V in Master/Slave mode.

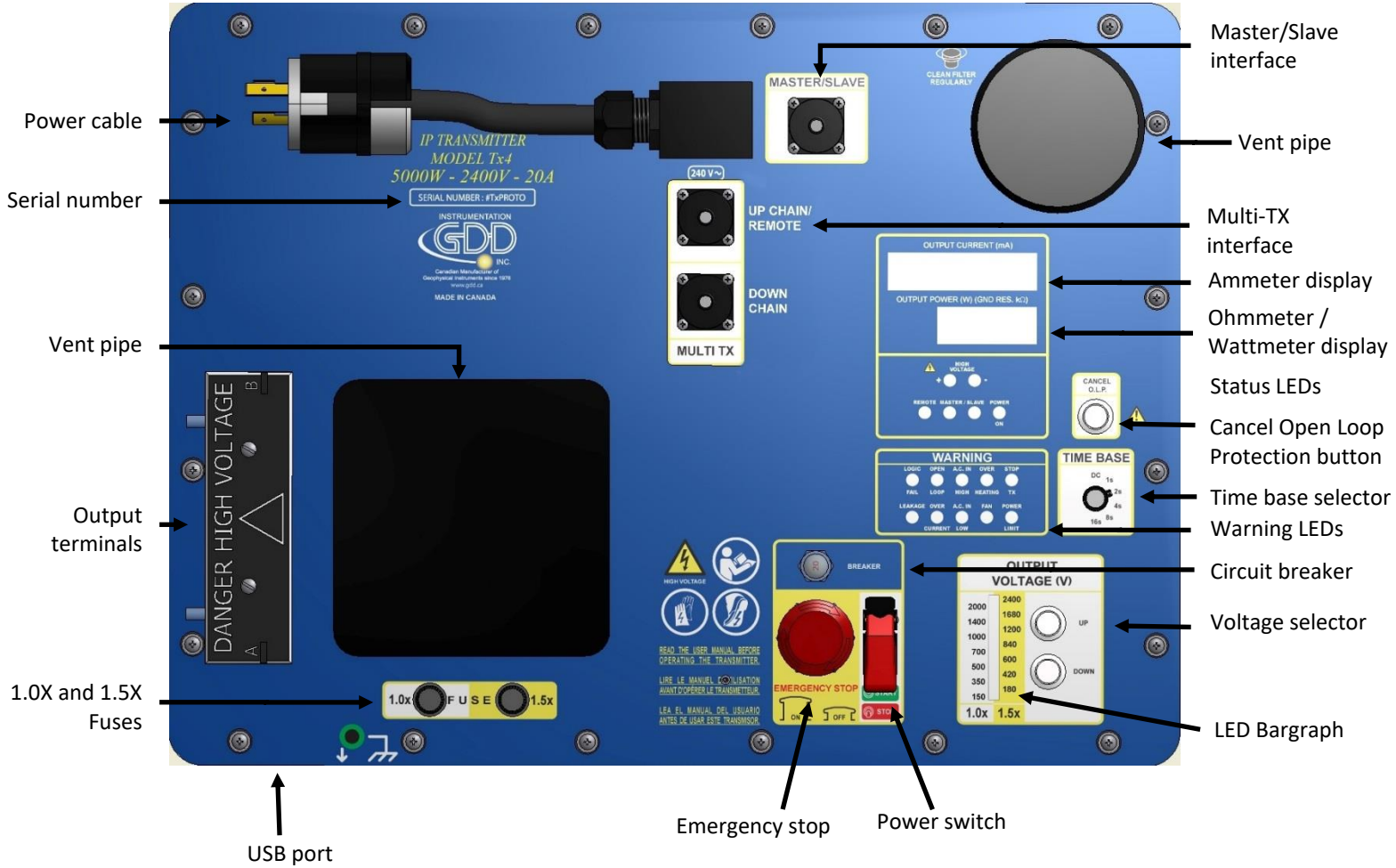

3.2.2 Power Cable

The end of the power cable can be plugged into any 220-240VAC / 50-60Hz voltage source. Please check transmitter's nameplate for specificity.

3.2.3 Serial number

Each instrument has its own serial number to identify it.

3.2.4 Master/Slave Interface

The Master/Slave interface allows linking two transmitters with a synchronization cable (optional Master/Slave cable) to increase the total output power and the output voltage of the system. The Tx4 model is compatible with TxII and TxIII models.

3.2.5 Multi-TX interface

The Multi-TX interface allows linking up to four (4) transmitters with a synchronization cable (optional Multi-TX cable) to increase the total output power and output voltage of the system. The Multi-TX interface is only compatible with the Tx4 model.

The UP CHAIN/REMOTE connector of the Master Tx4 unit can also be used to connect a GDD-RTE01 communication box (to broadcast the output current and power to a GDD IP receiver).

3.2.6 Status LEDs

The red lights indicate the following elements:

HIGH VOLTAGE: These LEDs blink to indicate the presence of high voltage on the output terminals, allowing the operator to follow the Tx4 transmission cycle.

MASTER: The transmitter is in stand-alone mode or in MASTER configuration.

SLAVE: The transmitter is in SLAVE configuration.

POWER ON: Indicates that the transmitter is powered on.

3.2.7 Ammeter Display

When the transmitter is running, the output current expressed in milliampere is indicated. The Tx4 output current display is refreshed every 500ms. (Refer to section 8 if using the Multi-TX mode).

3.2.8 Vent Pipes

There are two vent pipes (intake / exhaust) on the control panel. The FAN warning light indicates if the fan is running. Make sure that the airflow is not being obstructed by any object (e.g.: leaves, snow, etc.).

IMPORTANT: Check the filter inside the vent pipe regularly and clean it if necessary.

3.2.9 Ohmmeter and Wattmeter Display

GROUND RESISTANCE: Displays the ground resistance when the transmitter is powered OFF (power switch is toggled down (STOP) and the emergency button is pulled up). The value shown is the contact resistance in kilo-ohms ($\times 1000\Omega$). Below 5Ω , the ohmmeter will display "LO", referring to a low ground resistance. In Multi-TX mode, the ohmmeter is not activated and will display "OFF".

- OUTPUT POWER: When the transmitter is running, the output power expressed in Watt is indicated in place of the contact resistance. The displayed power is the average power measured while the transmitter is ON. (Refer to section 8 if using the Multi-TX mode).

3.2.10 Cancel Open Loop Protection (O.L.P.) Button

The GDD Tx4 has an internal open loop protection circuit to prevent direct electric shock to the operator. This protection is triggered when the electrodes are not connected to the output terminals, or when the current is less than 30mA.

NOTE: If the ground has a very high resistivity, the open loop protection could disrupt the signal's transmission. To temporarily cancel the O.L.P. turn the Tx4 OFF, press the Cancel O.L.P. button and turn the Tx4 ON within the next 5 seconds. The ohmmeter display will temporarily display "COL" and the open loop led will blink while the cancel-open-loop is activated.

3.2.11 Time Base Selector

The time base selector allows the following modes: DC, 1s, 2s, 4s, 8s and 16s. The DC mode allows the transmitter to work as a constant voltage source (unipolar).

3.2.12 Warning LEDs

The red lights indicate the following problems:

LOGIC FAIL: Caused by an internal electronic failure.

LEAKAGE: This alarm is triggered when there is a synchronization problem (example: current detected through the unit during OFF time). The leakage alarm may also be triggered if the survey is carried out over a very chargeable environment.

OPEN LOOP: There is a very high resistance between the two output terminals (the circuit is opened) or the output current is less than 30mA (highly resistive ground). The open loop led is blinking while the cancel-open-loop is activated.

OVER CURRENT: The rated current limit is exceeded. The current limit is set to 20A in normal mode and 5A in DC mode.

A.C. IN HIGH: High ($\geq 290\text{VAC}$) or irregular voltage from the generator. An unregulated generator can trigger this alarm. The power transformer may overheat.

A.C. IN LOW: Low ($\leq 170\text{VAC}$) or irregular voltage from the generator. An unregulated generator can trigger this alarm.

OVERHEATING: The internal temperature of the transmitter is too high ($\geq 85^{\circ}\text{C}$). Leave the transmitter ON and avoid transmitting while the fan is running until the LED turns off to let it cool off.

FAN: The fan is running. The fan starts to cool down the transmitter automatically when the temperature inside the transmitter is higher than 65°C .

STOP TX: This indicator lights up along with the warning LEDs indicating that the transmitter has stopped transmitting.

POWER LIMIT: The rated power limit has been exceeded. This limit is set to 5000W.

3.2.13 Voltage Selector

Use the UP and DOWN buttons to set the output voltage. The selected voltage scale will temporarily be recalled on the ohmmeter display.

The current voltage setting is always visible on the LED bar graph display. When the transmitter is not running, only a single LED indicates the voltage setting. The LEDs below that setting will light up once the Tx4 starts its transmission cycle.

The last selected voltage scale is kept in memory, even when the power source is disconnected, allowing the transmitter to restart with the same setting. In order to quickly reset the output voltage

to the lowest voltage scale, both UP and DOWN buttons can be pressed simultaneously. The displays will indicate Reset and 150.

The available output voltages are:

- 1.0X mode: 150V, 350V, 500V, 700V, 1000V, 1400V and 2000V.
- 1.5X mode: 180V, 420V, 600V, 840V, 1200V, 1680V and 2400V.

3.2.14 Power Switch: ON / OFF

To turn on the transmitter, lift the switch guard and toggle up the switch in the START position. Toggle down the switch in the STOP position to turn off the transmitter. Pushing down the switch guard will also toggle down the power switch in the STOP position. If the transmitter is stopped but still powered (emergency button pulled up), the ground resistance circuit will be enabled (see 3.2.8 – Ohmmeter and wattmeter display). It is recommended to turn the Tx off during the transmission OFF time.

3.2.15 Emergency Stop

This button is a safety mechanism and must be used in an emergency situation. The emergency stop shuts down all power inside the transmitter and all functions are disabled including the measurement of the ground resistance.

Once the emergency stop button has been pushed down, three (3) conditions must be met to reset the transmitter and make it work normally:

- The transmitter must be powered by an external supply.
- The emergency stop button must be pulled up.
- The power switch must be in STOP position (down).

Once these three (3) steps have been done, turn on the transmitter using the power switch.

NOTE: When pressed down, the emergency stop will shut down and reset the entire Tx4 system.

3.2.16 Circuit Breaker

There is a built-in circuit breaker to protect the instrument from overloading.

3.2.17 Fuses holder

The 1.0X and 1.5X fuses protect the Tx4 from fault current and electrical overload damages. If the fuses need replacement, see the guidelines in the troubleshooting section.

3.2.18 USB port

The USB port can be used to update the Tx4 firmware.

4. TRANSMITTER OPERATION

4.1 Steps to follow

Here are the basic steps to operate a Tx4 in stand-alone mode:

1. Make sure that the Tx4 is powered OFF.
2. Drive the electrodes into the ground and connect them to the output terminals with insulated wires.
3. Start the generator.
4. Reset the emergency stop circuit (see section 3.2.14 – Emergency Stop).
5. Set the voltage selector to the lowest voltage scale (150V) and start the transmitter.
6. Increase the output voltage to increase the output power. It is not necessary to turn off the transmitter to change the voltage scale or select a different time base. Note that the transmitter will automatically stop if you try to transmit more than 5000W. In this case, select a lower voltage scale and power cycle the transmitter to reset the STOP TX alarm.

IMPORTANT:

- It is recommended to turn the transmitter OFF only when the “HIGH VOLTAGE” LED is off, which occurs in the OFF time of the cycle or when the STOP TX light is triggered.
- Turn the transmitter OFF before shutting down the generator.

4.2 Output Power

If a generator more powerful than 5000W is used, the output power will be limited to 5000W by the Tx4. If the generator used cannot deliver up to 5000W, such as a 700W generator, the output power will be limited by the generator.

5. GENERATOR CONNECTION

5.1 Single-phase Connection

The transmitter is intended to be powered from a single-phase generator. The rated input voltage is 240VAC. The following picture shows the wiring diagram of the power cable. Note that the polarity of the connection is not important.

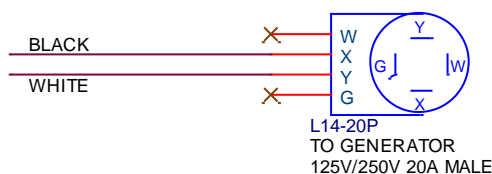

5.2 Three-phase Basics

The types of three-phase configurations are Delta (Δ) and Star (Y):

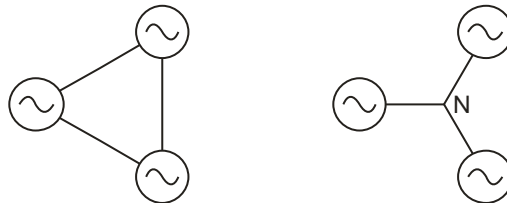

Delta and Star three-phase connection

The star configuration might have a neutral connection. However, the delta configuration doesn't have a neutral connection. There is a $\sqrt{3}$ factor between the line to line voltage and the line to neutral voltage - i.e. for a $230V_{LN}$ generator, the line to line voltage would be $400V_{LL}$.

5.3 Transmitter Connection to a three-phase Generator

Damages due to a bad connection to a three-phase generator will not be covered by the warranty.

As the rated input voltage of the transmitter is 240VAC, precautions must be taken when connecting to a three-phase generator. The following connection diagram is provided for a 400V_{LL} generator. Only a generator which has a neutral connection available can be used with the transmitter. The line-neutral voltage is 230VAC. Make sure not to connect the transmitter to a line to line connection. Bad connections could damage the instrument. Do not use the ground connection instead of the neutral. If two transmitters are going to be used, an additional line to neutral connection can be made with a different phase. Note that the polarity of the connection is not important.

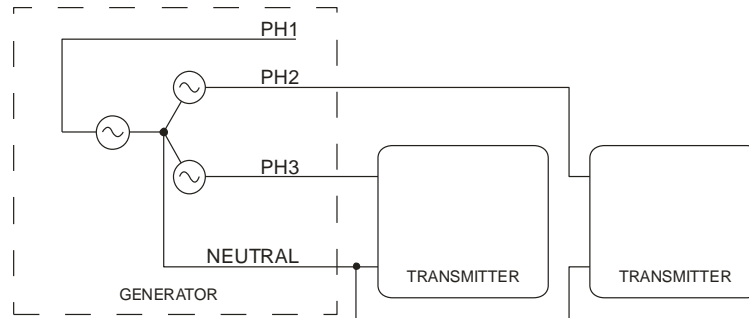

6. Updating the Firmware

Requirements

- PC running on Windows equipped with a USB port
- Standard USB type A male to type B male cable
- Firmware update file .xml
- Firmware Downloader tool FlashTool.exe

1. Connect the type B connector of the Tx4 to a PC using the USB-A/B cable.

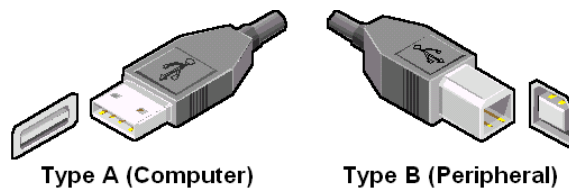

2. Power on the Tx4 i.e. Connect the Tx4 to a 220/240V source of power and put the Emergency Switch to ON (up ↑).
3. Copy the program *FlashTool.exe* on your computer. Make sure to keep the associated .dll files in the same folder than the .exe file. Double click on the program to open it.



4. In the main window, click on **Select File** and select the firmware update file (.xml).

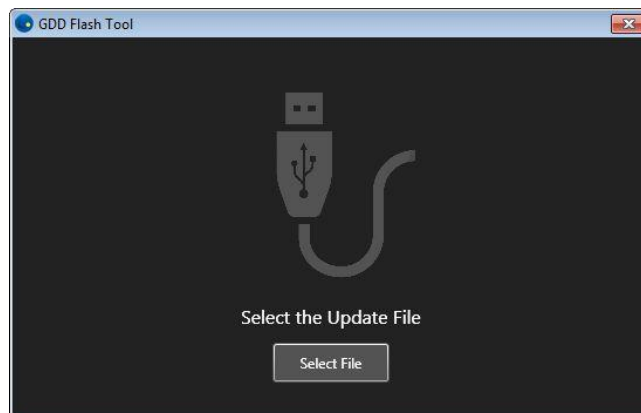

5. Click on the Update! button to begin the update.
6. If the following error occurs make sure that the Tx4 is powered on and that the USB Cable is connected to the computer.

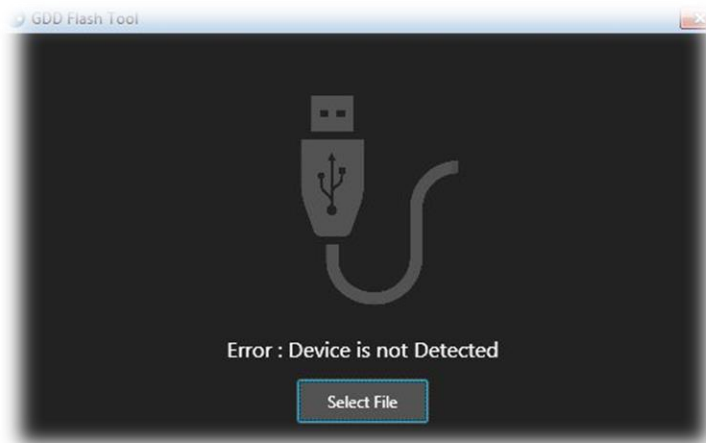

7. The update process may take a few minutes to complete. Do not disconnect your device until the update has finished.

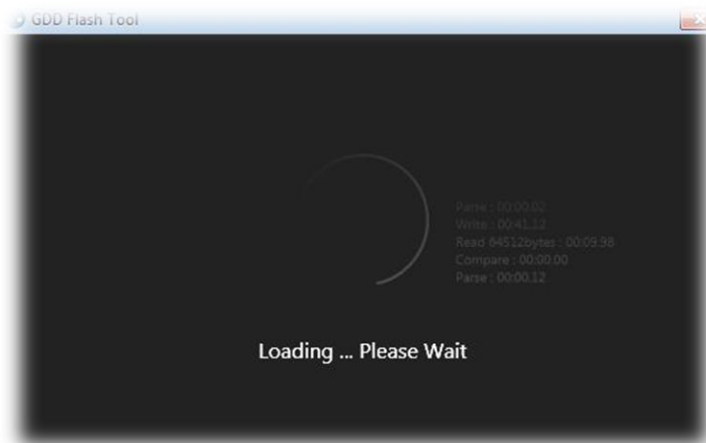

8. Once successfully completed, the following message will be displayed:

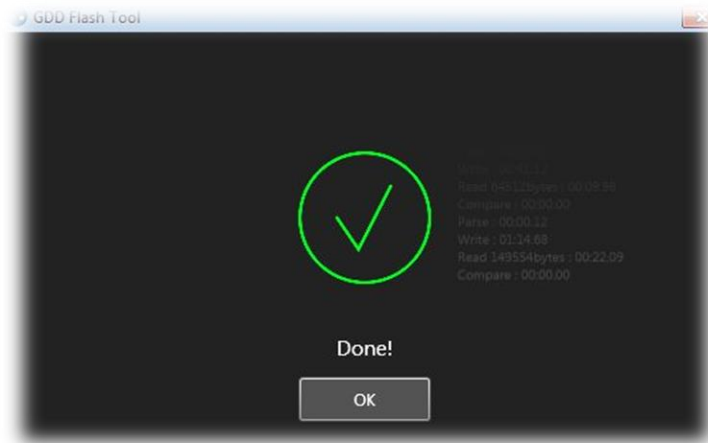

9. Upon completion, re-start the Tx4 pushing down and then up the Emergency Switch (↑↓).
10. While starting up, the Tx4 Current display will show **UPDATE**. Wait until the Contact Resistance display shows **DONE**.
11. Restart one last time the Tx4 pushing down and then up the Emergency Switch (↑↓).
12. Firmware update is now completed.

7. MASTER / SLAVE MODE

In Master/Slave mode, the output power and output voltage of each Tx will be combined to reach 10,000W and 4800V. On the other hand, the output current will not be combined.

Here are the basic steps for a Master/Slave operation of the Tx4:

1. Connect the yellow synchronization cable (Master/Slave) to the transmitters. The Master/Slave cable terminations are different: one is labeled *MASTER* and the other one *SLAVE*. The transmitter is *MASTER* or *SLAVE* according to the termination of the cable connected to its interface. The *MASTER* and *SLAVE* LEDs indicate the mode of each transmitter. (see figure 2, yellow line)
2. Connect an insulated wire between the terminal (A) of one transmitter and the terminal (B) of the other one. (see figure 2, red line)
3. Connect the two power cables from the transmitters to the generator(s). (see figure 2, black lines)
4. Drive the electrodes into the ground and connect them to the unused terminals (A) and (B) by using insulated wires. (see figure 2, red lines)

Figure 2

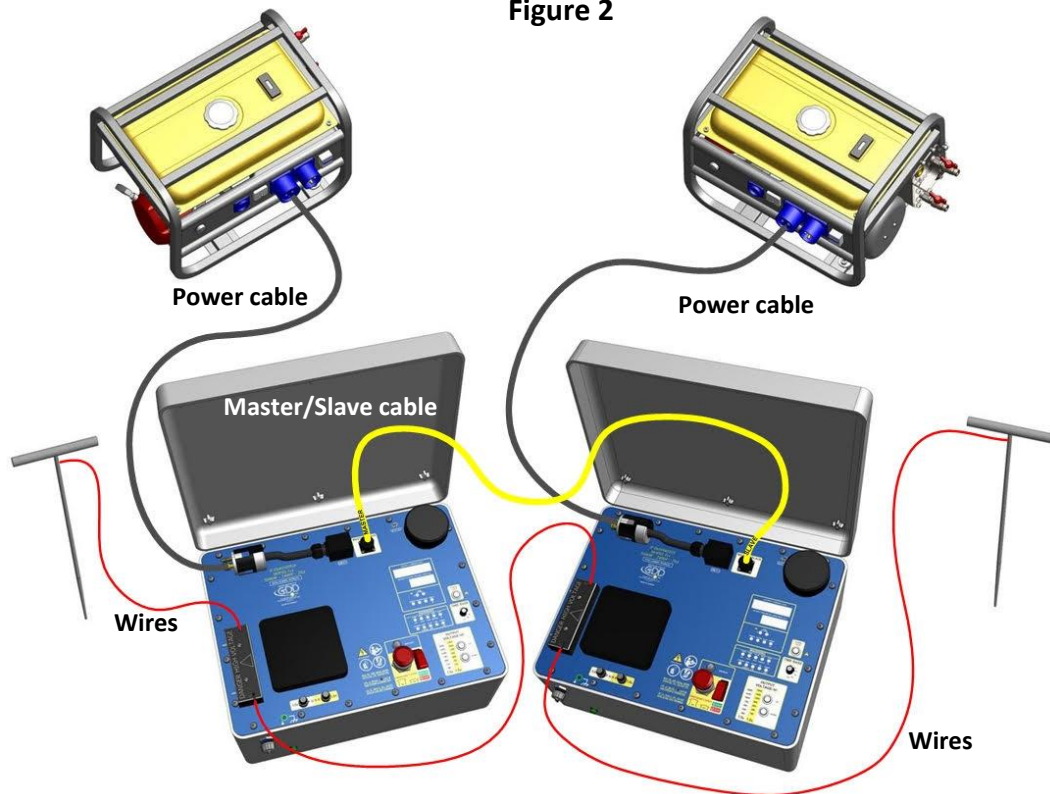

5. Make sure that the voltage selector is at the minimum scale (150V) on both transmitters.
6. Turn on both transmitters.
7. Gradually increase the output voltages from one transmitter to the other until the transmitters stop due to a power limit.

Note: The selected voltage scale on the two transmitters should not be more than one step different in order to have a transmitted power by both units that is as close as possible.

8. Reduce the output voltage of one transmitter by one step with the voltage selector.
9. Start the transmission cycle.

NOTES on Master/Slave mode

- If the Master/Slave cable is not connected, the transmitter will work in stand-alone mode.
- It is possible to reach 4800V with two transmitters in a Master/Slave system.

- The current displayed on both transmitters should be the same ($\pm 0.1A$).
- **With the current Tx4 software version (1.0), the following limitation apply if the combination Tx4 – TxII is used: the Tx4 unit must be the SLAVE and turned ON (START) before the TxII (MASTER).**

8. MULTI-TX MODE

In Multi-TX mode, the output power of each Tx4 unit is combined to reach a maximum of 20,000W with four (4) transmitters. The output voltage will be combined to reach a maximum of 4800V, even if using more than two (2) Tx4 units. Lastly, the maximum output current will always be 20A.

Here are the basic steps for a Multi-Tx operation of the Tx4:

- a) The Multi-TX cable terminations are different: one is labeled UP (up chain) and the other one DOWN (down chain). The transmitter is *MASTER* or *SLAVE* according to the termination of the cable connected to its interface. The *MASTER* and *SLAVE* LEDs indicate the mode of each transmitter.
- b) To define the *MASTER* transmitter, connect the Multi-TX cable to the *down chain* connector. The other end of the cable must be connected to the *up chain* connector of the *SLAVE 1* transmitter. The subsequent *SLAVES* (2, 3, ...) transmitters must be connected in the same manner by connecting another Multi-TX cable from the *SLAVE X down chain* to the *SLAVE X+1 up chain* (see figure 3, yellow lines)
- c) Connect an insulated wire between the terminal (A) of the *MASTER* transmitter and the terminal (B) of the *SLAVE 1* transmitter. Connect the subsequent *SLAVES* (2, 3, ...) with an insulated wire between the terminal (A) of the *SLAVE X* transmitter and the terminal (B) of the *SLAVE X+1* transmitter (see figure 3, red lines).
- d) Connect the power cables from the transmitters to the generator(s) (see figure 3, black lines).
- e) Drive the electrodes into the ground and connect them to the unused terminals (A) and (B) by using insulated wires (see figure 3, red lines).
- f) Make sure that the voltage selector is at the minimum scale (150V) on each transmitter.
- g) Turn on each transmitter.
- h) Gradually increase the output voltage at the *MASTER* unit. All the *SLAVES* will be set instantaneously to the same voltage. Each *SLAVE* can modify its own voltage output in order to adjust more accurately the total output voltage of the Multi-Tx chain.

Note: The selected voltage scale on each transmitter should not be more than one step different in order to have a transmitted power by all units that is as close as possible.
- i) Start the transmission cycle.

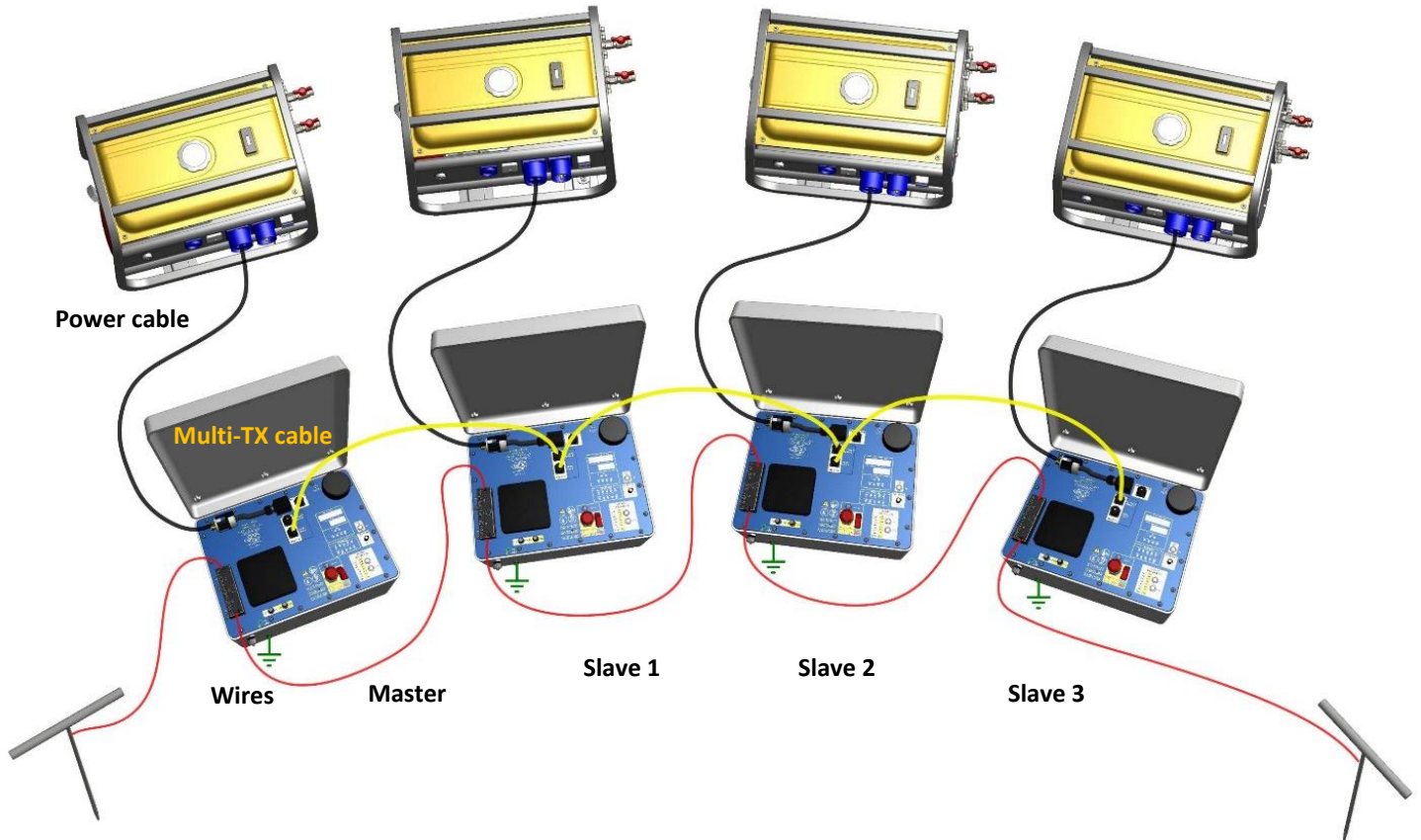

***** PLEASE READ CAREFULLY *****

Use with TRM

The Multi-TX interface and the TRM are compatible but **the user must limit the maximum voltage to 2400V per TRM**. The TX CTRL cable of the TRM must be connected to the Master/Slave connector of the master of the Multi-TX chain. The Slaves must be connected with the Multi-TX cables (not via the Master/Slave connector).

Use with TX Controller

The Multi-TX interface and the TX Controller are compatible. The Master/Slave cable must be connected to the Master/Slave connector of the master of the Multi-TX chain. The “Master” end must be connected to the TX Controller. The Slaves must be connected with the Multi-TX cables (not via the Master/Slave connector).

Notes on Multi-TX interface

- a) When the power switch of the MASTER Tx4 transmitter is at the OFF position, the ammeter display is used to display the number of Tx in the Multi-Tx chain in the first two (2) digits and the total voltage of the Multi-Tx chain in the last four (4) digits.



4 TX in the Multi-TX chain with total nominal output voltage of 4800V

- b) When the power switch of the MASTER transmitter is at the ON position, the C.O.L. button is used to switch between the power of the MASTER (*SINGLE*) and the power of the Multi-Tx chain (*TOTAL*). The output power of the MASTER is displayed in watt (W) and the output power of the Multi-Tx chain is displayed in kilowatt (kW) : XX.XX kW.



Master outputs 488W



MTX chain outputs 0.94kW

- By default, the output power displayed at the MASTER Tx is in *SINGLE* mode
- c) If the voltage output is modified on the MASTER, all the SLAVES will be set instantaneously to the same voltage. Each SLAVE can modify its own voltage output in order to adjust more accurately the total output voltage of the Multi-Tx chain.
 - d) The Cancel Open-Loop of the whole chain is activated via the C.O.L. button on the MASTER.
 - e) The current displayed on each transmitter should be the same ($\pm 0.1A$).

9. TROUBLESHOOTING

With a good understanding of the transmitting circuit and a little logic, most of the problems that will happen with the Tx4 can often be resolved.

1- Nothing seems to work

The ON LED is not illuminated and the displays remain blank: check if the power source (generator) is working properly. Check also the power cable and the extension cord. The breaker might also be tripped.

2- The ON LED is illuminated but the Tx4 does not transmit

Check if a warning LED is also illuminated:

LOGIC FAIL: Indicates that an internal electronic failure occurred. Reset the transmitter by pushing down the Emergency switch. If it doesn't work, move the Tx4 away from the current electrodes.

LEAKAGE: Power cycle the transmitter. If it doesn't work, move the Tx4 away from the current electrodes.

Note: False alarms can also occur in some cases such as a poorly regulated generator, a low supply voltage or, in some unlikely cases, proximity of the transmitter to the electrodes. False alarms can also be possible on a highly chargeable ground where the discharge is very slow, leading to a non-zero value during the whole OFF time. If this is the case, the remaining discharge voltage in the ground could potentially trigger the leakage alarm of the transmitter by injecting a small current in the TX when the output polarity reverses at the end of the OFF time.

OPEN LOOP: Can be caused by a cut wire or by highly resistive ground. In such a case, you can bypass the open loop protection with the Cancel O.L.P. switch.

OVER CURRENT: The output current is too high. Decrease the output voltage or slightly pull the electrodes out of the ground.

A.C. IN (HIGH or LOW): Indicates that the power source (generator) is defective. The supply voltage must be stable and between 170VAC and 290VAC. Try to transmit less power with the Tx4 or change to another kind of generator.

WARNING: Always use a regulated generator. An unregulated generator could damage the instrument which would then not be covered by the warranty.

OVERHEATING: Indicates that the internal temperature of the Tx4 is too high. Don't turn the Tx4 OFF but leave it in this state to let the fan keep running to cool off the instrument.

POWER LIMIT: Decrease the output voltage.

STOP TX: This LED lights up when one of the previous problems is detected.

3- The Tx4 works well but the output power is very low

First, check if it is possible to increase the voltage. Every time you increase the voltage scale by two steps, the output power is approximately doubled. It is therefore possible to send 3000W at a given scale (e.g.: 6000mA at 500V) but the Tx4 will stop transmitting on the second next higher (e.g.: 8400mA at 700V) since it would try to transmit around 5880W. You may raise or lower the electrodes in the ground in order to alter the overall resistivity of the circuit. This could allow you to transmit 5000W at 700V.

4- Ground with very high resistivity

If the ground is highly resistive, it is possible that the output current is too low even at the maximum voltage. In such a case, you have to improve the electrode contact with the ground.

Here are a few suggestions:

- f) Move the electrodes to get a better contact;
- g) Double (or more) the number of electrodes;
- h) Pour water over the electrodes (with salt water if available).

5- Noise, Bad signal (Receiver)

The noise is an undesired interference or a disturbance that affects the signal. The source of noise may be a second IP or EM transmitter operating in the area; the interference zone may be as wide as 10 kilometers, depending on the power of the instrument and the system used. If a recurrent signal is received while the transmitter is powered off, this is certainly due to a second transmitter. The receiver could even synchronize with the undesirable signal if compatible.

Telluric currents may also cause the noise: they occur naturally near the surface of the earth and concentrate in conductive zones such as overburdens, shale or graphite formations, etc. To continue the survey in spite of telluric currents, improve the electrode contacts and increase the output current of the transmitter in order to increase the signal-to-noise ratio.

Finally, the noise may originate from a defective transmitter or receiver. First, check the electrodes, decrease the contact resistance and make sure there is no loose contact. The signal

timings of the receiver and the transmitter must be the same. If necessary, take a reading at a preceding station or repeat tests with another receiver or transmitter.

6- Resetting the control unit

If the IP Tx4 software is not responding (eg. Display is frozen, no output voltage or any unexpected behavior), the internal control unit can be reset by pushing down the Emergency Switch. The whole power supply will be shut down which will reset the control unit.

7- Radio interference

Radios can interfere with Tx4 units. It is thus recommended to keep a distance greater than 1.5m between the Tx4 interface and the radio while communicating with pairs.

8- Replacing the Fuses

Two 30 Amp fuses protect the transmitter from damage due to power surges and excessive current draw through the AC Control module. There are two independent power path for the transformer depending whether the TX is operated in 1.0X or 1.5X mode. Before replacing the fuses, check for the probable cause, such as improper generator voltage, then replace the defective fuse as follows:

1. Unplug the transmitter from the power outlet.



WARNING

REMOVE TRANSMITTER FROM POWER SOURCE PRIOR TO SERVICING THE FUSE. FAILURE TO COMPLY MAY RESULT IN INJURY AND/OR DAMAGE TO THE UNIT

2. Remove the twist lock cap from fuse holder.
3. Carefully remove the blown fuse from the retaining clip.
4. Remove the replacement fuse from the lid compartment and install it into fuse retaining clip. CAUTION: Never install a fuse with a different current/voltage rating.
5. Re-install the fuse into the holder.

10. TECHNICAL HELP

If you encounter a problem that can't be fixed or that is not described in the troubleshooting section, or for any other particular information, do not hesitate to contact us:

Instrumentation GDD

Phone: +1 (418) 478-5469

E-mail: info@gddinstruments.com

Any GDD Tx4 transmitter that breaks down while under warranty or service will be replaced free of charge upon request for the duration of repairs, subject to instruments availability, excluding shipping charges. Although this service is subject to instrument availability, we have been able to honour this commitment until now.

11. SPECIFICATIONS

Size:	Tx4-5000W with a blue carrying case: 34 x 52 x 76 cm Tx4-5000W only: 26 x 45 x 55 cm
Weight:	Tx4-5000W with a blue carrying case: ~ 53 kg Tx4-5000W only: ~ 40 kg
Operating Temperature:	-40°C to 65°C (-40°F to 150°F)
Transmission Cycle:	ON+, OFF, ON-, OFF
Time base:	DC, 1, 2, 4, 8 and 16 seconds
Output current:	0.030A to 20A (standard operation) 0.0A to 20A (open loop protection disabled) Maximum 5A in DC mode
Rated Output Voltage:	150V to 2400V Up to 4800V in a Master/Slave configuration
LED Displays:	Output current, 0.001A resolution Output power Ground resistance (when the transmitter is turned off)
Power source:	220-240V / 50-60Hz

12. GLOSSARY

Resistivity and Induced polarisation (IP) is a geophysical technique for which an electric current is transmitted into the ground and the voltage decay is monitored through electrodes or porous pots to measure its resistivity and chargeability. The GDD Tx4 is one of the principal components for an IP survey system.

Short circuit: Very low resistance connection between two nodes resulting in a fault current.

Transmitting circuit: The whole system associated with the Tx4: wires, electrodes, ground and transmitter.

Open circuit: Infinite resistance between two nodes. It is the electrical opposite of a short circuit.

Conductive ground: Ground with a low electrical resistivity. Such grounds are usually associated with thick overburden and the presence of water (e.g.: a swamp).

Resistive ground: Ground with a high electrical resistivity. Such grounds are usually associated with bare rock or sand.